

# EIPS2

## INTERNAL GEAR PUMPS



# Internal gear pump Type EIPS 2 with constant displacement volume



# EIPS 2

## Characteristics

- Internal gear pump with axial and radial gap compensation
- Radial compensation with segments
- Pressure cover
- Field of application: Mobile hydraulic systems, e.g. for fork lifts, industrial hydraulic
- Direct fixture
- Low noise
- Long time life
- Low pulsation (pressure pulsation ~ 2%)

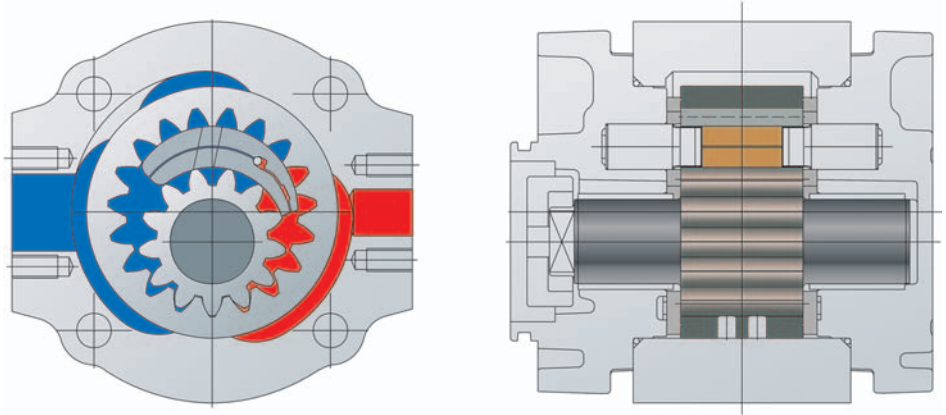

## Technical Data:

Rated Size NG	005	006	008	011	013	016	019	022	025
Spec. volume V <sub>th</sub> [cm <sup>3</sup> /rev]**	5.4	6.4	7.9	10.9	13.3	15.8	19.3	22.2	25.2
Continuous operating pressure [bar]	250								
Peak operating pressure [bar] max.10sec.15% duty cycle	320			300			280		
Cut-in pressure peak 100 ms [bar]	350			325			300		
Max. speed [min <sup>-1</sup> ]	4,200			4,000			3,600		
Nominal speed [min <sup>-1</sup> ]	200 – 4,000			200 – 3,600			100 – 3,000		
Operating viscosity [mm <sup>2</sup> /s]	10 – 300								
Starting viscosity [mm <sup>2</sup> /s]	2.000								
Operating temperature [°C]	-20 to +100								
Operating medium	HL – HLP DIN 51 524 Teil 1/2								
Max. medium temperature [°C]	120								
Min. medium temperature [°C]	-40								
Max. ambient temperature [°C]	80								
Min. ambient temperature [°C]	-40								
Max. admission pressure (intake side) [bar]	2 bar absolute								
Min. admission pressure (intake side) [bar]	0.8 bar absolute (start 0.6)								
Weight appr. [kg]	2.9	3.0	3.1	3.3	3.5	3.6	3.8	4.0	4.2
Degree of filtration	Class 20/18/15 due to ISO 4406								
Life expectancy	3 x 10 <sup>6</sup> LW against peak operating pressure								
Efficiency $\eta_{vol}$ [%]	91	92	93	93	94	95	95	95	95
Efficiency $\eta_{hm}$ [%]	90	90	91	92	92	93	93	93	93
Pump noise* (measured in sound chamber) dB[A]	55	56	58	59	60	61	62	63	64
	n = 1.450			$\Delta p = 250$ bar			T = 50 °C		Medium: HLP 46
	* Measured in anechoic room of Eckerle Hydraulic Division; Axial microphone distance 1.0 m								

\*\* Due to manufacturing tolerances the displacement volume could vary

# Dimensions



# EIPS 2

## Pump with oldham coupling

Order example: EIPS2 - \_\_\_LD34-1X

NG	a	b	c
005	43	82.5	72
006	44	84.5	74
008	45.5	87.5	77
011	48.5	93.5	83
013	51	98.5	88
016	53.5	103.5	93
019	57	110.5	100
022	60	116.5	106
025	63	122.5	112

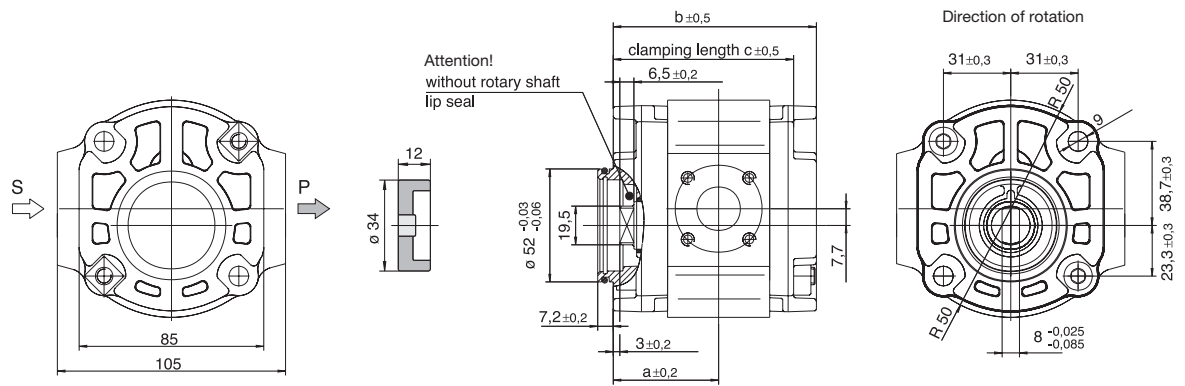

Coupling included in scope of delivery.  
Provide M8 DIN 912 fastening screws with DIN 433 plain washer, tightening torque M=25+5 Nm

## Pump with SAE-A-2-hole flange and splint shaft

Order example: EIPS2 - \_\_\_RB04-1X

NG	a	b
005	62	101.5
006	63	103.5
008	64.5	106.5
011	67.5	112.5
013	70	117.5
016	72.5	122.5
019	76	129.5
022 *	79	135.5
025 *	82	141.5

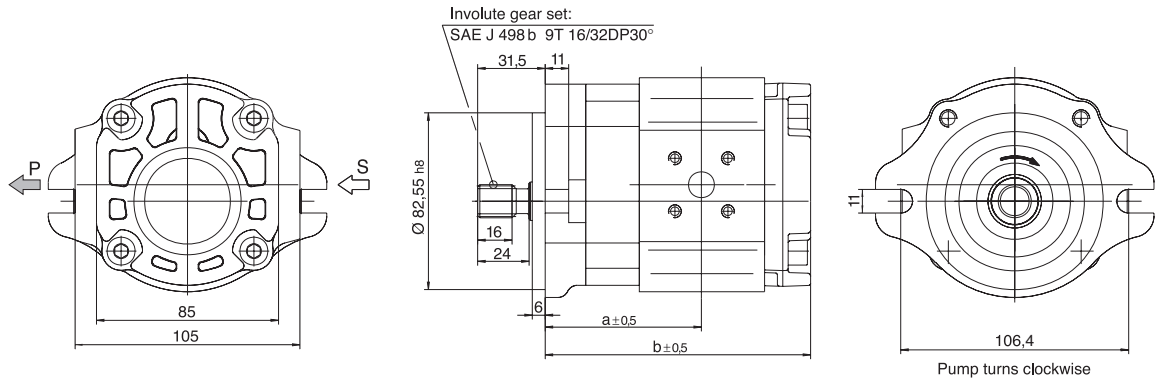

\*on request

## Pump with SAE-A-2-hole flange and cylindrical shaft

Order example: EIPS2 - \_\_\_RA04-1X

NG	a	b
005	62	101.5
006	63	103.5
008	64.5	106.5
011	67.5	112.5
013	70	117.5
016	72.5	122.5
019	76	129.5
022	79	135.5
025	82	141.5

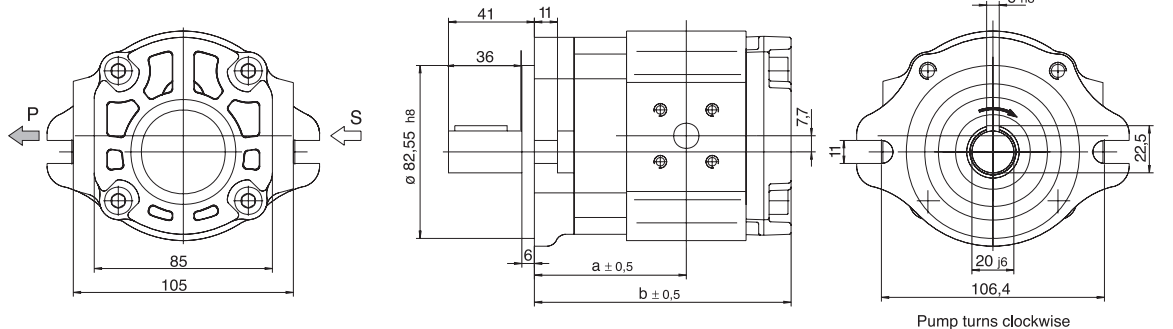

SAE-B flange on request



## Pump with cylindrical shaft

Order example: EIPS2 - \_\_ \_RA34-1X

NG	a	b	c
005	43	82.5	72
006	44	84.5	74
008	45.5	87.5	77
011	48.5	93.5	83
013	51	98.5	88
016	53.5	103.5	93
019	57	110.5	100
022	60	116.5	106
025	63	122.5	112

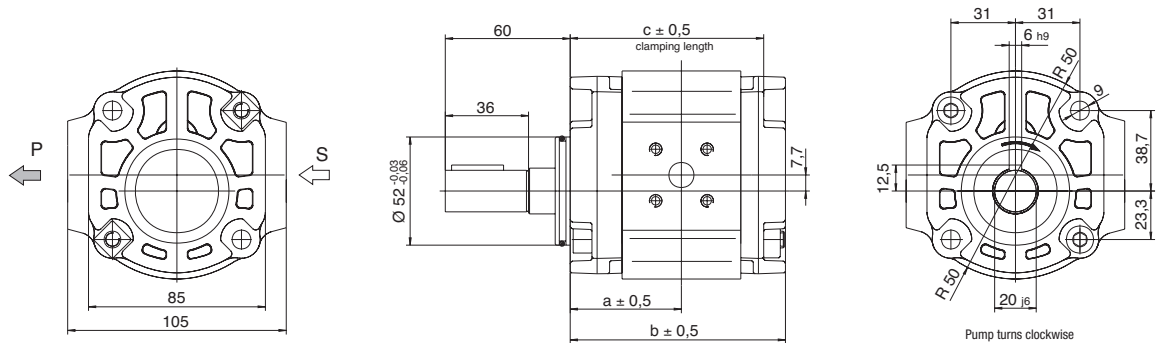

Provide M8 DIN 912 fastening screws with DIN 433 plain washer, tightening torque  $M=25+5$  Nm

## Doublepump with SAE-2-hole flange and cylindrical shaft

Order example: EIPS2 - \_\_ \_RK04-1X

EIPS2 - \_\_ \_RD34-1X

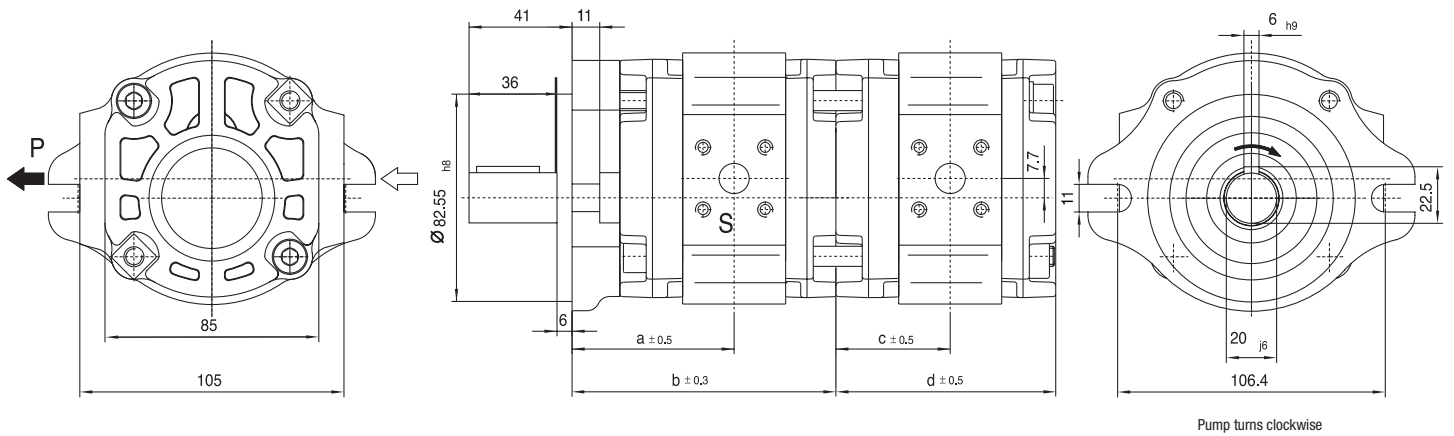

NG	a	b	c	d
005	62	100	43	82.5
006	63	102	44	84.5
008	64.5	105	45.5	87.5
011	67.5	111	48.5	93.5
013	70	116	51	98.5
016	72.5	121	53.5	103.5
019	76	128	57	110.5
022	79	134	60	116.5
025	82	140	63	122.5



## Pump with adaption, bold pattern of former Eckerle IPF 3 pumps

Order example: EIPPS2 - \_\_ \_\_ LD34-1X S112

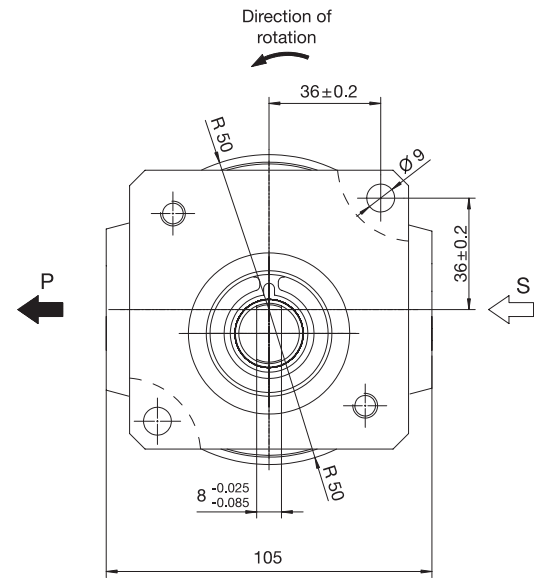
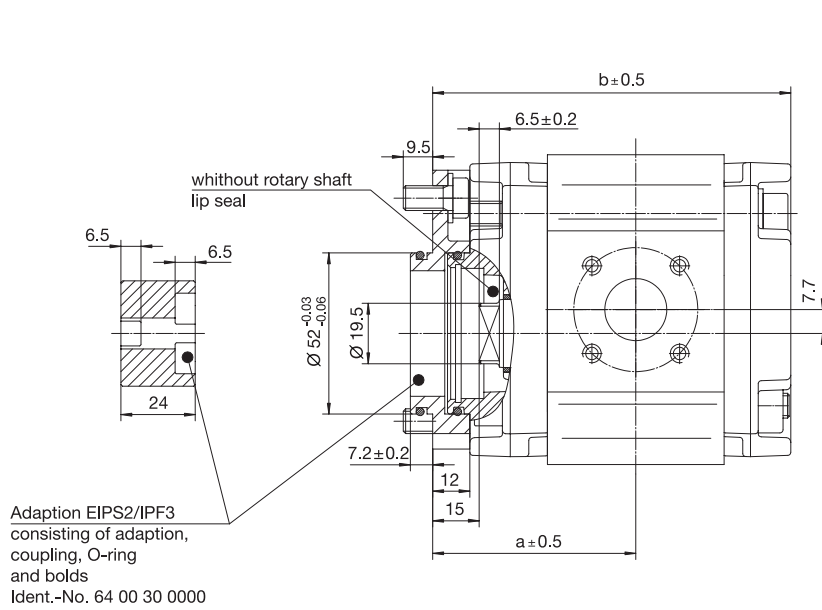

NG	a	b
011	60,5	105,5
013	63	110,5
016	65,5	115,5
019	69	122,5
022	72	128,5



## Flange connection 90° – 24° DIN 3901

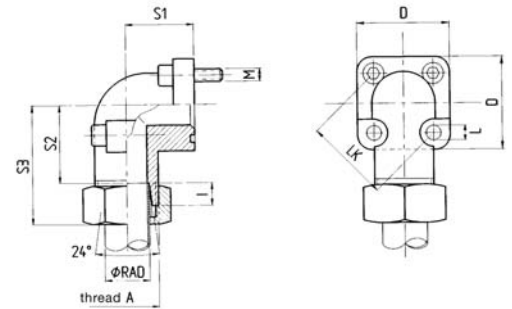

Type	Article number	LK	A	B	D	S1	S2	S3	L	Bolts	O-Ring	Weight	p max
WV-AD 12/35LK-C	0707040013	35	M18x1,5	14	39	16,5	30,5	47	6,4	2xM6x22 2xM6x35	20x2,5	0,13	315 bar
WV-AD 16/35LK-C	0707040014	35	M24x1,5	15	39	20	29,5	48	6,4	2xM6x22 2xM6x40	20x2,5	0,17	315 bar
WV-AD 28/40LK-C	0707040015	40	M36x2	20	42	28	32,5	49	6,4	2xM6x22 2xM6x50	26x2,5	0,27	100 bar
WV-AD 35/55LK-C	0707040016	55	M45x2	26	58	32	38,5	62	8,4	2xM8x25 2xM8x60	32x2,5	0,46	100 bar

## 4-hole flange 90° BSPP-threaded steel

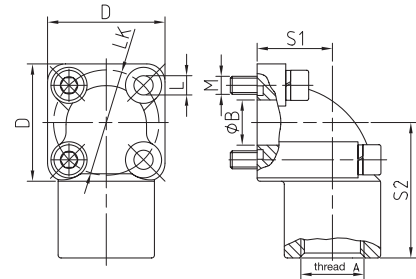

Type	Article number	LK	A	B	D	S1	S2	S3	L	Bolts	O-Ring	Weight	p max
WV-G3/8-35LK-C	0707040021	35	G1/8"	15	39	25	45		6,4	2xM6x22 2xM6x45	20x2,5	0,27	315 bar
WV-G1/2-35LK-C	0707040022	35	G1/2"	15	39	25	45		6,4	2xM6x22 2xM6x45	20x2,5	0,25	315 bar
WV-G3/4-40LK-C	0707040023	40	G3/4"	20	42	28	50		6,4	2xM6x22 2xM6x50	26x2,5	0,38	160 bar
WV-G1-55LK-C	0707040025	55	G1"	26	58	40	59		8,4	2xM6x25 2xM6x70	32x2,5	0,87	160 bar

## Flange connection – straight 24° DIN 3901

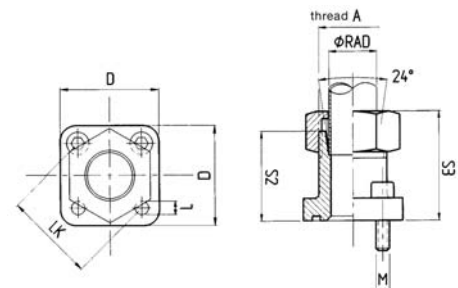

Type	Article number	LK	A	B	D	S1	S2	S3	L	Bolts	O-Ring	Weight	p max
V-AD 12/35LK-C	0707040017	35	M18x1,5	11	39	30	39		6,4	4xM6x22	20x2,5	0,09	315 bar
V-AD 16/35LK-C	0707040018	35	M24x1,5	12	39	30	39,5		6,4	4xM6x22	20x2,5	0,11	315 bar
V-AD 28/40LK-C	0707040019	40	M36x2	20	42	42	44,5		6,4	4xM6x22	26x2,5	0,16	100 bar
V-AD 35/55LK-C	0707040020	55	M45x2	28	55	50	61		8,4	4xM8x25	32x2,5	0,3	100 bar



Intake and delivery connections

Intake connection

NG 005-016

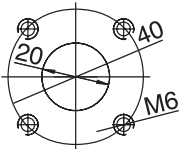

NG 019-025

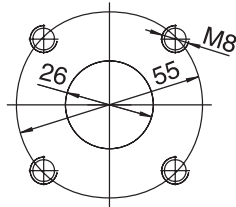

Delivery connection

NG 006-025

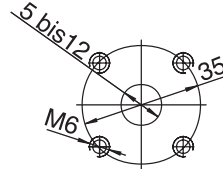

Thread depth M6 and M8 = 12 mm  
All dimensions stated in mm  
– other connections on request –

**EIP S2-011RA34-10 S123**

Special version number (not applicable with standard pumps or when the type key is unambiguous)

Revision code 1st number: Change of mounting dimensions  
2nd number: Change of pump with same mounting dimensions

Intake and delivery connection 4: Square flanged connection in accordance with DIN 3901/3902  
– other connections on request –

Fastening flange: 0: SAE-A-2-hole centre-Ø 82.55  
2: SAE-B-2-hole centre-Ø 101.6  
3: Direct fixture  
– other flanges on request –

Shaft end A: Cylindrical  
B: SAE gear  
D: Two-flange engagement  
K: Cylindrical with cone  
L: SAE gear with cone  
N: Two-flange engagement with cone  
(cone = add-on facility for additional pumps to create multiple-flow pumps)

Sense of rotation R: Clockwise  
L: Anticlockwise

Rated size, three digits

Overall size

Type S: Segmental pump

Eckerle internal gear pump

Order example

**EIPS2 - 005 LD34 - 1X**

Segmental pump overall size 2 with 5.4 cm<sup>3</sup>/rev., anti-clockwise rotation, two-flange engagement, direct fixture, square flange connection, revision code 10



## Volumetric flow

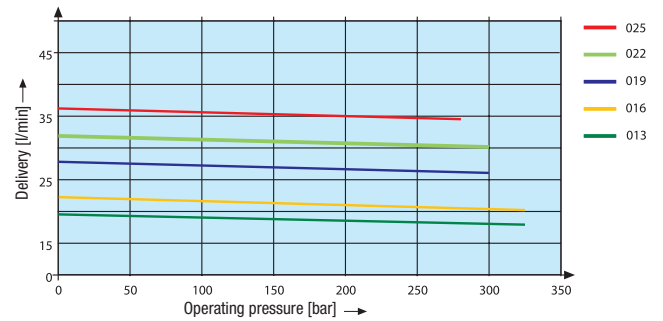
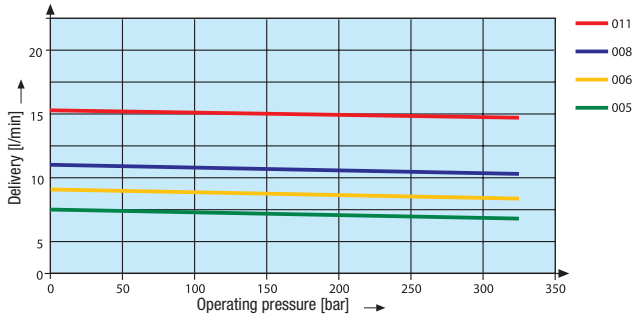

## Efficiency

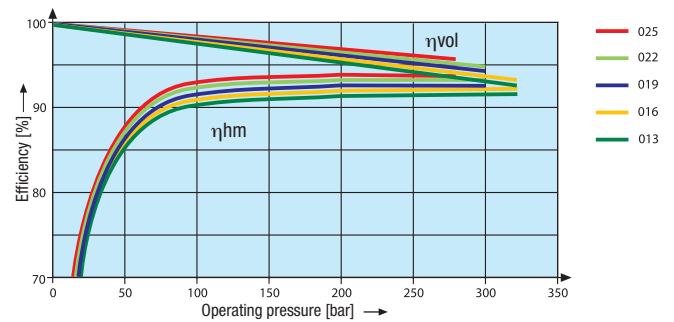
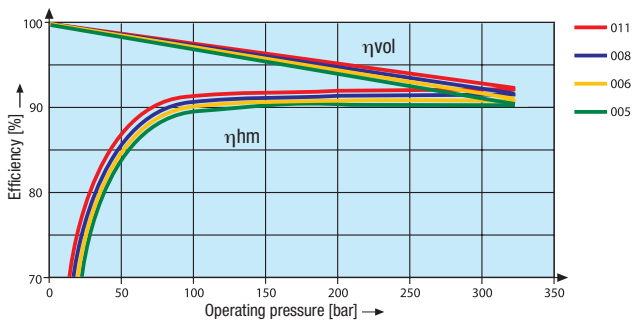

## Drive power

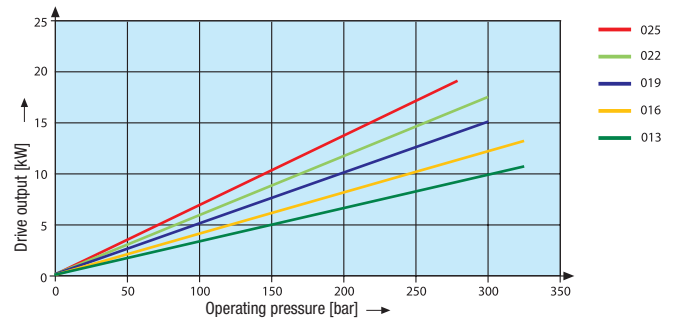
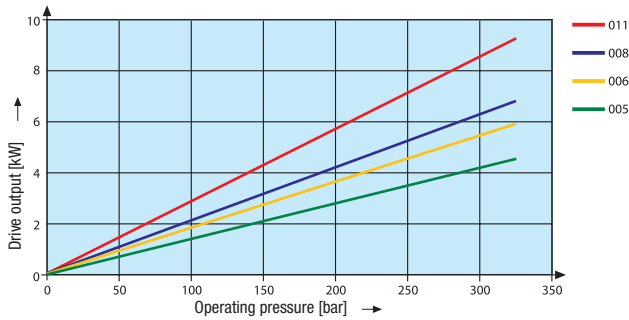

## Sound pressure level

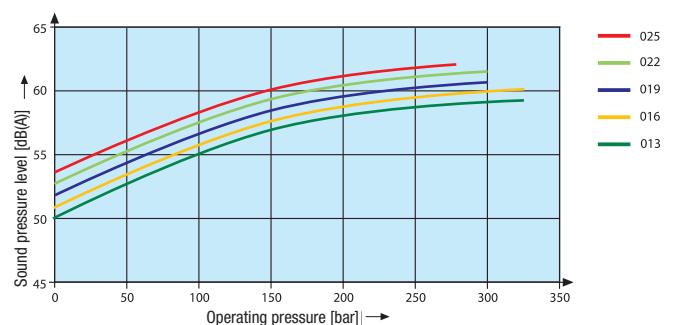
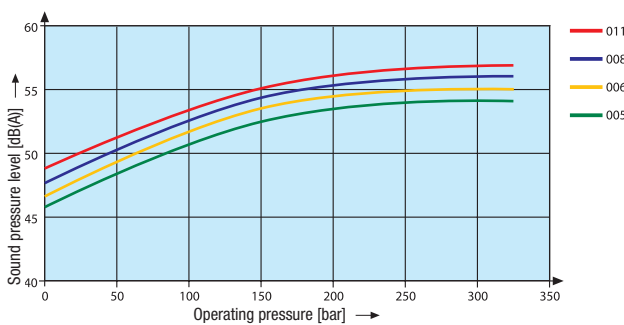

Measurement conditions: Speed 1450 rpm, viscosity 46 mm<sup>2</sup>/sec., operating temperature 40 °C

Sound pressure measured in low-reflection anechoic room in accordance with DIN 45 635 sheet 26;

Microphone distance 1.0 m axial.